



# Cambridge IGCSE™

---

**COMPUTER SCIENCE****0478/13**

Paper 1

**October/November 2021**

MARK SCHEME

Maximum Mark: 75

---

**Published**

This mark scheme is published as an aid to teachers and candidates, to indicate the requirements of the examination. It shows the basis on which Examiners were instructed to award marks. It does not indicate the details of the discussions that took place at an Examiners' meeting before marking began, which would have considered the acceptability of alternative answers.

Mark schemes should be read in conjunction with the question paper and the Principal Examiner Report for Teachers.

Cambridge International will not enter into discussions about these mark schemes.

Cambridge International is publishing the mark schemes for the October/November 2021 series for most Cambridge IGCSE™, Cambridge International A and AS Level components and some Cambridge O Level components.

---

This document consists of **8** printed pages.

**Generic Marking Principles**

These general marking principles must be applied by all examiners when marking candidate answers. They should be applied alongside the specific content of the mark scheme or generic level descriptors for a question. Each question paper and mark scheme will also comply with these marking principles.

**GENERIC MARKING PRINCIPLE 1:**

Marks must be awarded in line with:

- the specific content of the mark scheme or the generic level descriptors for the question
- the specific skills defined in the mark scheme or in the generic level descriptors for the question
- the standard of response required by a candidate as exemplified by the standardisation scripts.

**GENERIC MARKING PRINCIPLE 2:**

Marks awarded are always **whole marks** (not half marks, or other fractions).

**GENERIC MARKING PRINCIPLE 3:**

Marks must be awarded **positively**:

- marks are awarded for correct/valid answers, as defined in the mark scheme. However, credit is given for valid answers which go beyond the scope of the syllabus and mark scheme, referring to your Team Leader as appropriate
- marks are awarded when candidates clearly demonstrate what they know and can do
- marks are not deducted for errors
- marks are not deducted for omissions
- answers should only be judged on the quality of spelling, punctuation and grammar when these features are specifically assessed by the question as indicated by the mark scheme. The meaning, however, should be unambiguous.

**GENERIC MARKING PRINCIPLE 4:**

Rules must be applied consistently, e.g. in situations where candidates have not followed instructions or in the application of generic level descriptors.

**GENERIC MARKING PRINCIPLE 5:**

Marks should be awarded using the full range of marks defined in the mark scheme for the question (however; the use of the full mark range may be limited according to the quality of the candidate responses seen).

**GENERIC MARKING PRINCIPLE 6:**

Marks awarded are based solely on the requirements as defined in the mark scheme. Marks should not be awarded with grade thresholds or grade descriptors in mind.

Question	Answer	Marks								
1(a)	<p><b>One</b> mark for the correct tick</p> <table border="1"> <thead> <tr> <th>File Size</th> <th>Tick (✓)</th> </tr> </thead> <tbody> <tr> <td>999 kB</td> <td></td> </tr> <tr> <td>1 MB</td> <td>✓</td> </tr> <tr> <td>850 000 bytes</td> <td></td> </tr> </tbody> </table>	File Size	Tick (✓)	999 kB		1 MB	✓	850 000 bytes		1
File Size	Tick (✓)									
999 kB										
1 MB	✓									
850 000 bytes										
1(b)	<p><b>One</b> mark for the correct tick</p> <table border="1"> <thead> <tr> <th>File Size</th> <th>Tick (✓)</th> </tr> </thead> <tbody> <tr> <td>4000 MB</td> <td></td> </tr> <tr> <td>2 GB</td> <td>✓</td> </tr> <tr> <td>2 500 000 kB</td> <td></td> </tr> </tbody> </table>	File Size	Tick (✓)	4000 MB		2 GB	✓	2 500 000 kB		1
File Size	Tick (✓)									
4000 MB										
2 GB	✓									
2 500 000 kB										

Question	Answer	Marks								
2(a)	<p><b>One</b> mark for correct binary value, <b>one</b> mark for leading zeros</p> <p>00000000 01000111</p>	2								
2(b)	<p><b>One</b> mark for leading zeros, <b>one</b> mark for correct binary value</p> <p>00000001 00000001</p>	2								
2(c)	– 0516	1								
2(d)(i)	<ul style="list-style-type: none"> <li>– Pressure sensor</li> <li>– Motion sensor</li> </ul>	2								
2(d)(ii)	<p><b>One</b> mark for the correct tick</p> <table border="1"> <thead> <tr> <th>Device</th> <th>Tick (✓)</th> </tr> </thead> <tbody> <tr> <td>input</td> <td>✓</td> </tr> <tr> <td>storage</td> <td></td> </tr> <tr> <td>output</td> <td></td> </tr> </tbody> </table>	Device	Tick (✓)	input	✓	storage		output		1
Device	Tick (✓)									
input	✓									
storage										
output										

Question	Answer	Marks																								
3(a)	<p><b>One</b> mark per each row</p> <table border="1"> <thead> <tr> <th>Statement</th> <th>ARQ (✓)</th> <th>Check digit (✓)</th> <th>Checksum (✓)</th> </tr> </thead> <tbody> <tr> <td>checks for errors on data entry</td> <td></td> <td>✓</td> <td></td> </tr> <tr> <td>uses a process of acknowledgement and timeout</td> <td>✓</td> <td></td> <td></td> </tr> <tr> <td>compares two calculated values to see if an error has occurred</td> <td></td> <td>✓</td> <td>✓</td> </tr> <tr> <td>may resend data until it is confirmed as received</td> <td>✓</td> <td></td> <td></td> </tr> <tr> <td>checks for errors in data after transmission from a computer to another</td> <td></td> <td></td> <td>✓</td> </tr> </tbody> </table>	Statement	ARQ (✓)	Check digit (✓)	Checksum (✓)	checks for errors on data entry		✓		uses a process of acknowledgement and timeout	✓			compares two calculated values to see if an error has occurred		✓	✓	may resend data until it is confirmed as received	✓			checks for errors in data after transmission from a computer to another			✓	5
Statement	ARQ (✓)	Check digit (✓)	Checksum (✓)																							
checks for errors on data entry		✓																								
uses a process of acknowledgement and timeout	✓																									
compares two calculated values to see if an error has occurred		✓	✓																							
may resend data until it is confirmed as received	✓																									
checks for errors in data after transmission from a computer to another			✓																							
3(b)	– Parity check	1																								

Question	Answer	Marks
4(a)	<p>Any <b>four</b> from:</p> <ul style="list-style-type: none"> <li>– Printer generates interrupt</li> <li>– Interrupt is given a priority</li> <li>– Interrupt is queued</li> <li>– Interrupt stops <b>CPU</b> from processing current task</li> <li>– CPU will service interrupt // Interrupt handler services interrupt ...</li> <li>– ... generating an output message to state there is a paper jam</li> </ul>	4
4(b)	<p>Any <b>two</b> from:</p> <ul style="list-style-type: none"> <li>– A suitable description of any error that might occur</li> <li>– A peripheral is connected/disconnected</li> <li>– A key on a keyboard is pressed</li> <li>– A mouse button click</li> <li>– A phone/video call is received</li> <li>– A buffer requires more data</li> <li>– A printer runs out of paper</li> <li>– A printer runs out of ink</li> <li>– Opening an application</li> <li>– When switching from one application to another</li> </ul> <p><b>NOTE:</b> If two suitable different errors are described, this can be awarded two marks</p>	2

Question	Answer	Marks
4(c)(i)	<b>Four</b> from: <ul style="list-style-type: none"> <li>– Bits sent <b>one at a time</b></li> <li>– ... down a single wire</li> <li>– Data sent in both directions ...</li> <li>– ... but only one direction at a time</li> </ul>	<b>4</b>
4(c)(ii)	Any <b>two</b> from: <ul style="list-style-type: none"> <li>– Simplex only sends data in one direction</li> <li>– ... so, printer may not be able to tell computer an error has occurred, and computer may not be able to send printer the document to be printed</li> </ul> <p><b>NOTE:</b> Award any valid contextual answer for MP2</p>	<b>2</b>

Question	Answer	Marks														
5	<b>One</b> mark per correct term or description. <table border="1" style="width: 100%; border-collapse: collapse;"> <thead> <tr> <th style="width: 35%;">Component name</th> <th>Description</th> </tr> </thead> <tbody> <tr> <td>Memory Address Register (MAR)</td> <td>(A register that) holds the address of the data/instruction that needs to be fetched/processed // holds the address of where the data needs to be stored.</td> </tr> <tr> <td>Program Counter (PC)</td> <td>(A register that) holds the address of the <b>next / current instruction</b> to be processed.</td> </tr> <tr> <td>accumulator // ACC</td> <td>This is a register that is built into the arithmetic logic unit. It temporarily holds the result of a calculation.</td> </tr> <tr> <td>memory data register // MDR</td> <td>This is a register that holds data or an instruction that has been fetched from memory.</td> </tr> <tr> <td>Control Unit (CU)</td> <td>Sends control signals to control the flow of data through the CPU // manages the execution of instructions in the CPU</td> </tr> <tr> <td>address bus</td> <td>This carries addresses around the CPU.</td> </tr> </tbody> </table>	Component name	Description	Memory Address Register (MAR)	(A register that) holds the address of the data/instruction that needs to be fetched/processed // holds the address of where the data needs to be stored.	Program Counter (PC)	(A register that) holds the address of the <b>next / current instruction</b> to be processed.	accumulator // ACC	This is a register that is built into the arithmetic logic unit. It temporarily holds the result of a calculation.	memory data register // MDR	This is a register that holds data or an instruction that has been fetched from memory.	Control Unit (CU)	Sends control signals to control the flow of data through the CPU // manages the execution of instructions in the CPU	address bus	This carries addresses around the CPU.	<b>6</b>
Component name	Description															
Memory Address Register (MAR)	(A register that) holds the address of the data/instruction that needs to be fetched/processed // holds the address of where the data needs to be stored.															
Program Counter (PC)	(A register that) holds the address of the <b>next / current instruction</b> to be processed.															
accumulator // ACC	This is a register that is built into the arithmetic logic unit. It temporarily holds the result of a calculation.															
memory data register // MDR	This is a register that holds data or an instruction that has been fetched from memory.															
Control Unit (CU)	Sends control signals to control the flow of data through the CPU // manages the execution of instructions in the CPU															
address bus	This carries addresses around the CPU.															

Question	Answer	Marks
6	<b>One</b> mark per correct term in the correct order. <ul style="list-style-type: none"> <li>– MP4</li> <li>– MP3</li> <li>– Microphone</li> <li>– Compressed</li> <li>– MIDI</li> <li>– Notes</li> <li>– Can</li> </ul>	<b>7</b>

Question	Answer	Marks
7(a)	Any <b>four</b> from: <ul style="list-style-type: none"> <li>– Creates an executable file</li> <li>– ... so, would not release source code</li> <li>– ... so, the source code cannot be stolen/edited.</li> <li>– ... so, would not need to be translated every time // so, translator is not required</li> <li>– ... making it machine independent</li> </ul>	<b>4</b>
7(b)(i)	Any <b>three</b> from: <ul style="list-style-type: none"> <li>– Compression algorithm used</li> <li>– ..., e.g. RLE</li> <li>– Repeating frames/pixels are identified</li> <li>– ... and are collated/indexed</li> <li>– No data is <b>permanently</b> removed</li> <li>– It just records the changes between frames/pixels</li> </ul>	<b>3</b>
7(b)(ii)	Any <b>one</b> from: <ul style="list-style-type: none"> <li>– Maintains quality // quality better than lossy</li> <li>– Original file is retained // Data is not <b>permanently</b> lost</li> <li>– A significant reduction in file size is not required</li> </ul>	<b>1</b>
7(c)(i)	Any <b>four</b> from : (MAX 3 per software licence)  Freeware: <ul style="list-style-type: none"> <li>– User does not have access to the source code</li> <li>– Has copyright</li> <li>– User does not have the right to <b>edit</b> the software</li> <li>– Normally distributed for free // no cost</li> </ul> Free software: <ul style="list-style-type: none"> <li>– User has access to the source code</li> <li>– Still has copyright // Is copyleft</li> <li>– User has the right to <b>edit and share</b> the software</li> <li>– Normally has a fee // cost to buy</li> </ul>	<b>4</b>
7(c)(ii)	<ul style="list-style-type: none"> <li>– Distribute as shareware</li> </ul>	<b>1</b>
7(d)	Any <b>two</b> from: <ul style="list-style-type: none"> <li>– URL begins with HTTPS</li> <li>– Padlock symbol is locked</li> </ul>	<b>2</b>

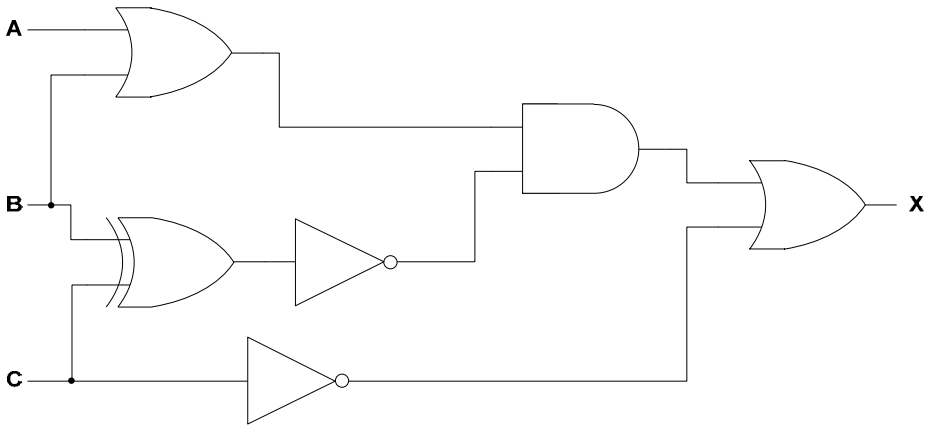
Question	Answer	Marks																																													
8(a)	<p><b>One</b> mark per each correct logic gate with correct inputs</p> 	<b>6</b>																																													
8(b)	<p>4 marks for 8 correct outputs                      3 marks for 6/7 correct outputs                      2 marks for 4/5 correct outputs                      1 mark for 2/3 correct outputs</p> <table border="1" data-bbox="306 958 1311 1547"> <thead> <tr> <th>A</th> <th>B</th> <th>C</th> <th>Working space</th> <th>X</th> </tr> </thead> <tbody> <tr> <td>0</td> <td>0</td> <td>0</td> <td></td> <td>1</td> </tr> <tr> <td>0</td> <td>0</td> <td>1</td> <td></td> <td>0</td> </tr> <tr> <td>0</td> <td>1</td> <td>0</td> <td></td> <td>1</td> </tr> <tr> <td>0</td> <td>1</td> <td>1</td> <td></td> <td>1</td> </tr> <tr> <td>1</td> <td>0</td> <td>0</td> <td></td> <td>1</td> </tr> <tr> <td>1</td> <td>0</td> <td>1</td> <td></td> <td>0</td> </tr> <tr> <td>1</td> <td>1</td> <td>0</td> <td></td> <td>1</td> </tr> <tr> <td>1</td> <td>1</td> <td>1</td> <td></td> <td>1</td> </tr> </tbody> </table>	A	B	C	Working space	X	0	0	0		1	0	0	1		0	0	1	0		1	0	1	1		1	1	0	0		1	1	0	1		0	1	1	0		1	1	1	1		1	<b>4</b>
A	B	C	Working space	X																																											
0	0	0		1																																											
0	0	1		0																																											
0	1	0		1																																											
0	1	1		1																																											
1	0	0		1																																											
1	0	1		0																																											
1	1	0		1																																											
1	1	1		1																																											

Question	Answer	Marks
9	<ul style="list-style-type: none"> <li>– Even</li> <li>– Even</li> <li>– Odd</li> <li>– Even</li> </ul>	<b>4</b>

Question	Answer	Marks
10(a)	– To disrupt the operation of a web server/network	<b>1</b>
10(b)	– To obtain a user's <b>personal</b> data	<b>1</b>
10(c)	Any <b>three</b> from: – Hacking // Cracking – Virus – Spyware – Malware	<b>3</b>