

Please write clearly in block capitals.

Centre number

Candidate number

Surname _____

Forename(s) _____

Candidate signature _____

A-level COMPUTER SCIENCE

Paper 2

Friday 15 June 2018

Morning

Time allowed: 2 hours 30 minutes

Materials

For this paper you must have:

- a calculator.



Instructions

- Use black ink or black ball-point pen.
- Fill in the boxes at the top of this page.
- Answer **all** questions.
- You must answer the questions in the spaces provided. Do not write outside the box around each page or on blank pages.
- Do all rough work in this book. Cross through any work you do not want to be marked.

Information

- The marks for questions are shown in brackets.
- The maximum mark for this paper is 100.

Advice

- In some questions you are required to indicate your answer by completely shading a lozenge alongside the appropriate answer as shown. 
- If you want to change your answer you must cross out your original answer as shown. 
- If you wish to return to an answer previously crossed out, ring the answer you now wish to select as shown. 

For Examiner's Use	
Question	Mark
1	
2	
3	
4	
5	
6	
7	
8	
9	
10	
11	
12	
13	
14	
15	
TOTAL	



Answer **all** questions.

Do not write
outside the
box

- 0 1 . 1** Shade **one** lozenge to indicate which of the unsigned numbers listed in **Table 1** has the largest value.

Table 1

Number base	Number	Largest value (shade one)
Binary	101101001	<input type="radio"/>
Hexadecimal	30A	<input type="radio"/>
Decimal	396	<input type="radio"/>

[1 mark]

Questions **01.2** and **01.3** use a **normalised** floating point representation with a 7-bit mantissa and a 5-bit exponent, both stored using **two's complement**.

The following is a floating point representation of a number:

0	●	1	0	1	1	0	0
---	---	---	---	---	---	---	---

Mantissa

1	1	1	0	1
---	---	---	---	---

Exponent

- 0 1 . 2** Calculate the decimal equivalent of the number. You **must** show your working.

[2 marks]

Answer _____



0 1 . 3

Write the normalised floating point representation of the decimal value -608 in the boxes below. You **must** show your working.

[3 marks]

Do not write
outside the
box

Answer

●					
---	--	--	--	--	--

Mantissa

--	--	--	--	--

Exponent

6

Turn over for the next question

Turn over ►



0 2

Figure 1 shows an image composed of four objects, represented digitally as a vector graphic. **Figure 2** shows the same image, represented digitally as a bitmap graphic.

The bitmap graphic has an image size of 50 x 50 pixels.

Each image uses four colours: white, black, yellow and blue.

Figure 1



Figure 2



0 2 . 1

Describe how a vector graphic is represented.

Include an explanation of how the black rectangle in **Figure 1** would be represented in your description.

[3 marks]



0 2 . 2

Calculate the minimum amount of storage space that is required to store the bitmap image in **Figure 2** excluding metadata. Express your answer in bytes.

You **must** show your working.

[2 marks]

Answer _____

Figure 3 shows an enlarged view of part of one row of pixels from the image in **Figure 2**.

Figure 3



0 2 . 3

Describe how a row of pixels, such as that shown in **Figure 3**, could be represented in compressed form by using run length encoding.

[2 marks]

Question 2 continues on the next page

Turn over ►



Figure 4 shows an image of a woodland scene.

Figure 4



0 2 . 4

The image in **Figure 2** is compressed using run length encoding. The compressed file is 80% smaller than the original file.

The image in **Figure 4** is compressed using the same technique and the compressed file is approximately the same size as the original file.

Explain why the run length encoding method was not able to compress the image in **Figure 4** as much as it could compress the image in **Figure 2**.

[2 marks]



0 3

Figure 5 shows a logic circuit.

Figure 5

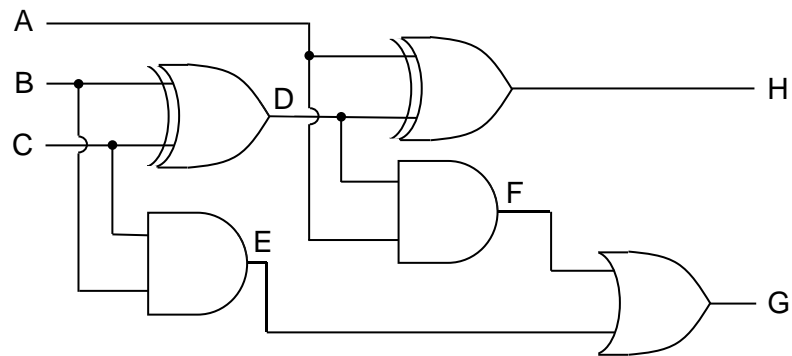

0 3 . 1

Complete the part of the truth table for the circuit in **Figure 5** that is shown below.

[3 marks]

Inputs			Outputs				
A	B	C	D	E	F	G	H
0	0	0					
0	0	1					
0	1	1					
1	1	1					

0 3 . 2

Using **Figure 5**, write a Boolean expression to show how the output **G** is calculated from the inputs **A**, **B** and **C**.

[3 marks]

G = _____

0 3 . 3

Explain the purpose of the circuit.

[1 mark]

Turn over ►



0 5 . 3

When a device wishes to join **Subnet Z** it communicates with the DHCP server.

Explain:

- the purpose of the DHCP system
- why the DHCP system is used
- what will happen during this communication.

[4 marks]

Question 5 continues on the next page

Turn over ►



0 5 . 4

The web server, which has the IP address 192.168.16.12, must be accessible from computers that are connected to the Internet but outside the company's own network.

As the web server has a non-routable IP address, it cannot be accessed directly from outside the network. Therefore, access to the web server will be facilitated by the External Router, which supports Network Address Translation (NAT) and port forwarding.

Explain how the External Router will have been configured so that the web server can be accessed by computers outside the network.

[2 marks]

8

0 6 . 1

Describe the principles of operation of an optical disk drive that is used to read data from an optical disk such as a CD-ROM or DVD-ROM.

[6 marks]



0 6 . 2

USB Flash Drives (a type of SSD) are a more popular choice for transferring files such as images and word processed documents from one computer to another than CD-Rs (a type of optical disk).

Explain why this is the case.

[1 mark]

7

0 7

Athletes, who are members of teams, compete in running events, which are held at fixtures throughout the year.

For example, athlete 15 might compete in the Girls' 1500m Under 18 race in the fixture at Marsten on 12 September 2018.

A relational database is used to store the details of which athletes enter each event at each fixture. The relations used in the database are shown in **Figure 7**.

Figure 7

Athlete(AthleteID, Surname, Forename, DateOfBirth, Gender, TeamName)

EventType(EventTypeID, Gender, Distance, AgeGroup)

Fixture(FixtureID, FixtureDate, LocationName)

EventAtFixture(FixtureID, EventTypeID)

EventEntry(FixtureID, EventTypeID, AthleteID)

- Each Athlete, EventType and Fixture is identified by a unique identity number, for example AthleteID for athletes.
- An EventType is a type of event, such as Boys' 100m Under 15 race.
- If an athlete wants to take part in an event at a particular fixture, then an entry is created in the EventEntry relation to represent this.

Question 7 continues on the next page

Turn over ►



07.1

Figure 8 shows an incomplete entity-relationship diagram for part of the database.

Draw lines on **Figure 8** to show the degree of any **three** relationships that exist between the four entities shown.

[2 marks]

Figure 8

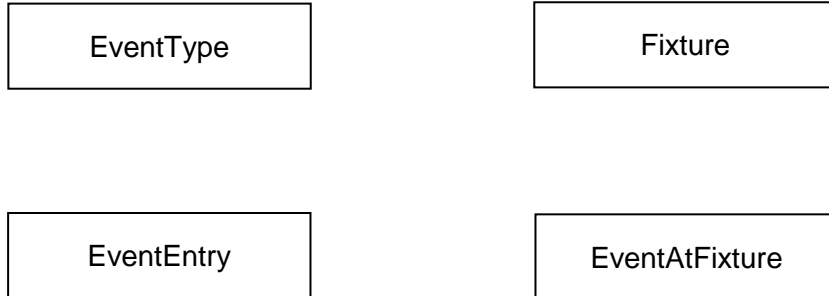

07.2

Figure 9 shows an SQL statement that is intended to make a table to represent the Athlete relation. The statement contains some errors.

Figure 9

```
CREATE TABLE Athlete (
    PRIMARY KEY AthleteID,
    VARCHAR(50) Surname,
    VARCHAR(30) Forename,
    DATE DateOfBirth,
    VARCHAR(6) Gender,
    VARCHAR(30) TeamName
)
```

You may assume that all of the data types used in **Figure 9** are valid and the field lengths are appropriate.

State **two** errors that have been made.

[2 marks]

Error 1: _____

Error 2: _____



07.3

State **two** reasons why database designs, such as this one, are usually normalised.

[2 marks]

Reason 1: _____

Reason 2: _____

Figure 7 is repeated below.

Figure 7 (repeated)

Athlete(AthleteID, Surname, Forename, DateOfBirth, Gender, TeamName)

EventType(EventTypeID, Gender, Distance, AgeGroup)

Fixture(FixtureID, FixtureDate, LocationName)

EventAtFixture(FixtureID, EventTypeID)

EventEntry(FixtureID, EventTypeID, AthleteID)

A list is to be produced of the names of all athletes who are competing in the fixture that is taking place on 17/09/18. The list must include the Surname, Forename and DateOfBirth of these athletes and no other details. The list should be presented in alphabetical order by Surname.

07.4

Write an SQL query to produce the list.

[5 marks]



Do not write outside the box

0 8

Explain some of the challenges that face legislators in the digital age.

[3 marks]

3

0 9 . 1

Three numbers are listed in the first column of **Table 2**.

For each row in **Table 2**, shade one or more lozenges, in the appropriate column(s), to indicate which set(s) of numbers contain(s) the number on the row.

As an example, the first row has been completed for you, to indicate that π is a member of the set of irrational numbers and the set of real numbers, but is not a member of the sets of natural, integer or rational numbers.

[2 marks]

Table 2

	Natural	Integer	Rational	Irrational	Real
π	<input type="radio"/>	<input type="radio"/>	<input type="radio"/>	<input checked="" type="radio"/>	<input checked="" type="radio"/>
15/23	<input type="radio"/>	<input type="radio"/>	<input type="radio"/>	<input type="radio"/>	<input type="radio"/>
108	<input type="radio"/>	<input type="radio"/>	<input type="radio"/>	<input type="radio"/>	<input type="radio"/>



0 9 . 2 Figure 10 shows a list of eight numbers, stored in an array.

Figure 10

Index	[0]	[1]	[2]	[3]	[4]	[5]	[6]	[7]
Contents	48	9	201	62	82	92	30	72

Describe what an ordinal number is **and** what an ordinal number would be used for in the context of this array.

[2 marks]

4

1 0 Using the laws of Boolean algebra, show that:

$$(A + B) \cdot (B + C \cdot (D + \bar{D})) = A \cdot C + B$$

You **must** show your working.

[4 marks]

4

Turn over for the next question

Turn over ►



1 1

Figure 11 shows an analogue signal represented as a waveform. The analogue signal is being converted to a digital signal by an analogue to digital convertor (ADC).

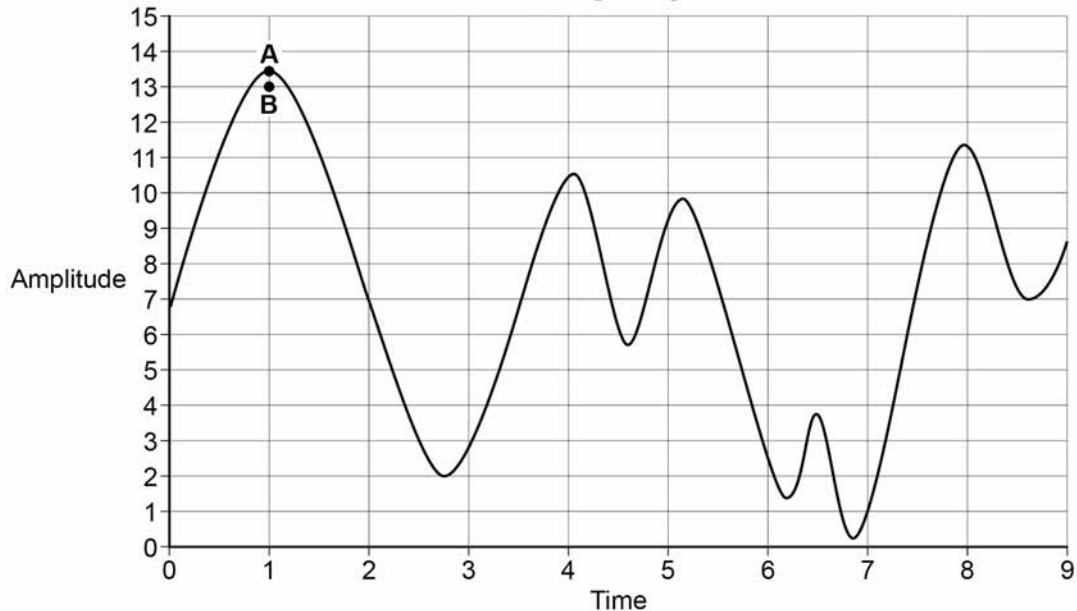
Figure 11**Analogue signal**

Points **A** and **B** in **Figure 11** indicate the amplitude of the waveform (**A**), at a point in time, and the value that was recorded for this measurement when the waveform was sampled (**B**).

1 1 . 1

The waveform's amplitude is measured and recorded using a scale with 16 divisions, which are shown on the Y axis in **Figure 11**.

The recorded digital data indicates which division on the Y axis each measurement is closest to. For example, the closest division to measurement **A** is 13.

What sample resolution has been used?

[1 mark]

1 1 . 2

The graph covers a time period of 0.01 seconds. During this time period, 10 samples have been recorded at the times indicated by the divisions on the X axis in **Figure 11**.

What sample rate has been used?

[1 mark]



1 1 . 3

Explain the impact of the difference between **A** and **B** and how this difference could be reduced by redesigning the sampling system.

[2 marks]

1 1 . 4

A different analogue signal is being sampled. The highest frequency present in the signal's waveform is 1200 Hz.

What is the minimum sample rate that must be used during sampling in order to preserve all of the frequencies in the waveform?

[1 mark]

5

Turn over for the next question

Turn over ►

1 2

The pseudo-code in **Figure 12** shows one method for carrying out encryption of a single character using the Caesar Cipher.

If the character to be encrypted is a capital letter, then the encrypted character will be shifted along the alphabet by the number of positions specified by the key. If the character is not a capital letter, then the encrypted character is set to be equal to the original character.

The pseudo-code assumes that the letter to encrypt is stored using the Unicode UTF-8 encoding method, for which the values of capital letters (in decimal) are shown in **Table 3**.

Figure 12

```

IF characterCode >= 65 AND characterCode <= 90 THEN
  encryptedCode ← characterCode + keyValue
  IF encryptedCode > 90 THEN
    encryptedCode ← encryptedCode - 26
  ENDIF
ELSE
  encryptedCode ← characterCode
ENDIF

```

Table 3

A	65	N	78
B	66	O	79
C	67	P	80
D	68	Q	81
E	69	R	82
F	70	S	83
G	71	T	84
H	72	U	85
I	73	V	86
J	74	W	87
K	75	X	88
L	76	Y	89
M	77	Z	90

Figure 13 shows an incomplete assembly language program that has been written to implement the pseudo-code algorithm shown in **Figure 12**. The assembly language instruction set that has been used to write the program is listed in **Table 4** on **page 22**.

The symbols ❶ and ❷ indicate the positions of missing lines of code.



Figure 13

	CMP R1, #65
	BLT doNotEncrypt
	CMP R1, #90
	BGT doNotEncrypt
	ADD R3, R1, R2
②	
①	doNotEncrypt:
	finished:
	HALT

1 | 2 | 1

By analysing the assembly language program in **Figure 13**, explain the purpose for which the registers R1, R2 and R3 have been used.

[2 marks]

Register	Purpose
R1	
R2	
R3	

1 | 2 | 2

On **Figure 13**, write the assembly language instruction that is missing from position ①.

[1 mark]

1 | 2 | 3

On **Figure 13**, write the assembly language instructions that are missing from position ②.

[3 marks]

6

Turn to page 23 for the next question

Turn over ►



Table 4 – Standard AQA assembly language instruction set

LDR Rd, <memory ref>	Load the value stored in the memory location specified by <memory ref> into register d.
STR Rd, <memory ref>	Store the value that is in register d into the memory location specified by <memory ref>.
ADD Rd, Rn, <operand2>	Add the value specified in <operand2> to the value in register n and store the result in register d.
SUB Rd, Rn, <operand2>	Subtract the value specified by <operand2> from the value in register n and store the result in register d.
MOV Rd, <operand2>	Copy the value specified by <operand2> into register d.
CMP Rn, <operand2>	Compare the value stored in register n with the value specified by <operand2>.
B <label>	Always branch to the instruction at position <label> in the program.
B<condition> <label>	Branch to the instruction at position <label> if the last comparison met the criterion specified by <condition>. Possible values for <condition> and their meanings are: EQ: equal to NE: not equal to GT: greater than LT: less than
AND Rd, Rn, <operand2>	Perform a bitwise logical AND operation between the value in register n and the value specified by <operand2> and store the result in register d.
ORR Rd, Rn, <operand2>	Perform a bitwise logical OR operation between the value in register n and the value specified by <operand2> and store the result in register d.
EOR Rd, Rn, <operand2>	Perform a bitwise logical XOR (exclusive or) operation between the value in register n and the value specified by <operand2> and store the result in register d.
MVN Rd, <operand2>	Perform a bitwise logical NOT operation on the value specified by <operand2> and store the result in register d.
LSL Rd, Rn, <operand2>	Logically shift left the value stored in register n by the number of bits specified by <operand2> and store the result in register d.
LSR Rd, Rn, <operand2>	Logically shift right the value stored in register n by the number of bits specified by <operand2> and store the result in register d.
HALT	Stops the execution of the program.

Labels: A label is placed in the code by writing an identifier followed by a colon (:). To refer to a label, the identifier of the label is placed after the branch instruction.

Interpretation of <operand2>

<operand2> can be interpreted in two different ways, depending on whether the first character is a # or an R:

- # – use the decimal value specified after the #, eg #25 means use the decimal value 25.
- Rm – use the value stored in register m, eg R6 means use the value stored in register 6.

The available general purpose registers that the programmer can use are numbered 0 to 12.



1 3

A family uses a wireless computer network at home.

1 3 . 1

Describe **two** security measures that the family should put in place to ensure that the wireless access point is secure **and** explain how these security measures will make wireless connections to the access point more secure.

[2 marks]

Measure 1: _____

Measure 2: _____

Question 13 continues on the next page

Turn over ►



1 4 . 2

In a fact-based model, data is represented as atomic facts, which are immutable (ie will never change). Fact-based models can be represented visually using a graph schema.

Figure 14 shows part of a graph schema for a data set about deliveries made to stores by trucks.

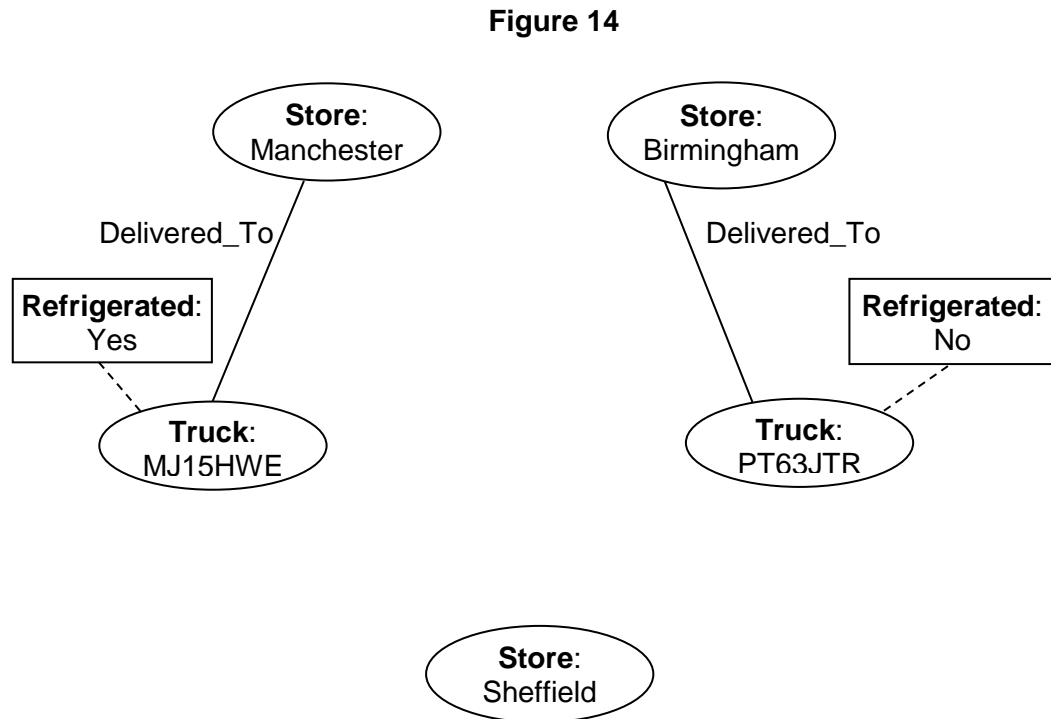

Complete the graph schema in **Figure 14** to represent the following additional facts.

- Truck MJ15HWE has made a delivery to the Sheffield store.
- Truck PT63JTR was last serviced on 10 May 2018 and truck MJ15HWE was last serviced on 18 March 2018.
- Both of the trucks are owned by a haulage company called Ferguson's which has 15 employees and has a head office in Bolton.

[3 marks]

5

Turn over for the next question

Turn over ►



1 5

In a functional programming language, four functions named `fw`, `fx`, `fy` and `fz` and a list named `sales` are defined as shown in **Figure 15**.

Figure 15

```
fw [a,b] = a * b
fx c = map fw c
fy d = fold (+) 0 d
fz e = fy (fx e)

sales = [[10,2], [2,25], [4,8]]
```

The `sales` list represents all of the sales made in a shop in 1 day. It is composed of sublists.

The values in each sublist indicate the price of a product and the quantity of the product that was sold. For example, `[10, 2]` indicates that 10 units of a product priced at £2 were sold.

1 5 . 1

Shade **one** lozenge to indicate how many of the four functions (`fw`, `fx`, `fy`, `fz`) in **Figure 15** use a higher-order function.

[1 mark]

1	<input type="radio"/>	2	<input type="radio"/>	3	<input type="radio"/>	4	<input type="radio"/>
---	-----------------------	---	-----------------------	---	-----------------------	---	-----------------------

1 5 . 2

Calculate the results of making the function calls listed in **Table 5**, using the functions and lists in **Figure 15** as appropriate.

[3 marks]**Table 5**

Function call	Result
<code>fw [4,3]</code>	
<code>fx sales</code>	
<code>fz sales</code>	



1	5	.	3
---	---	---	---

In the context of the shop, explain what the result of the function call `fz sales` represents.

[1 mark]

*Do not write
outside the
box*

5

END OF QUESTIONS



There are no questions printed on this page

*Do not write
outside the
box*

**DO NOT WRITE ON THIS PAGE
ANSWER IN THE SPACES PROVIDED**

Copyright information

For confidentiality purposes, from the November 2015 examination series, acknowledgements of third party copyright material will be published in a separate booklet rather than including them on the examination paper or support materials. This booklet is published after each examination series and is available for free download from www.aqa.org.uk after the live examination series.

Permission to reproduce all copyright material has been applied for. In some cases, efforts to contact copyright-holders may have been unsuccessful and AQA will be happy to rectify any omissions of acknowledgements. If you have any queries please contact the Copyright Team, AQA, Stag Hill House, Guildford, GU2 7XJ.

Copyright © 2018 AQA and its licensors. All rights reserved.

